



When, why and how?,
A guide to supply chain opportunities in electric machines

Dr David Simkin
david.simkin@warwick.ac.uk



When: Electrification for EVs driven by legislation and cost

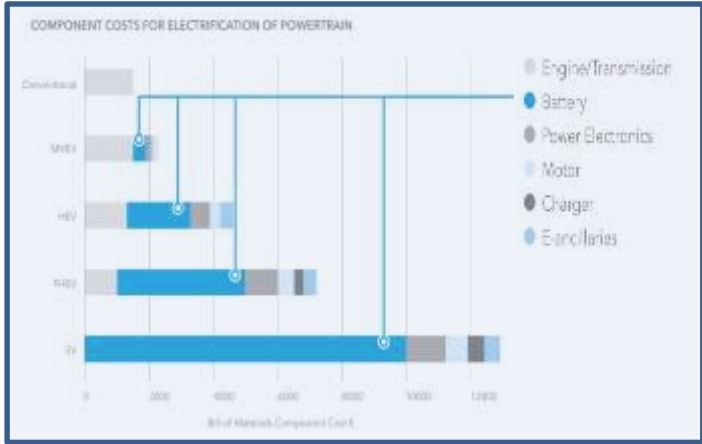
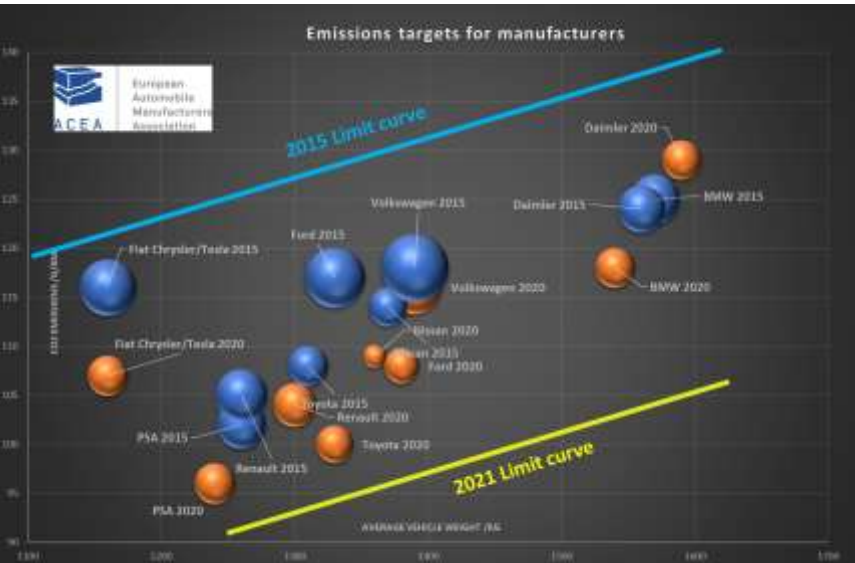

Electrification It will happen for automotive by 2035

Challenges exit for manufacturers

Opportunities exist for suppliers

How?



 **WMG**
THE UNIVERSITY OF WARWICK

Integration of the automotive powertrain



E-machine parts



General Motors
Permanent Magnet Electric Motor

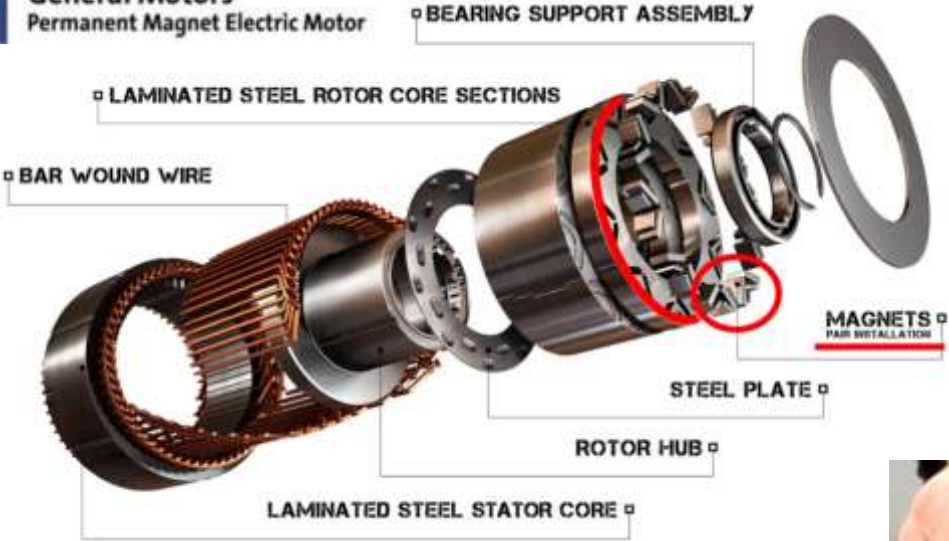

Market opportunities: Components

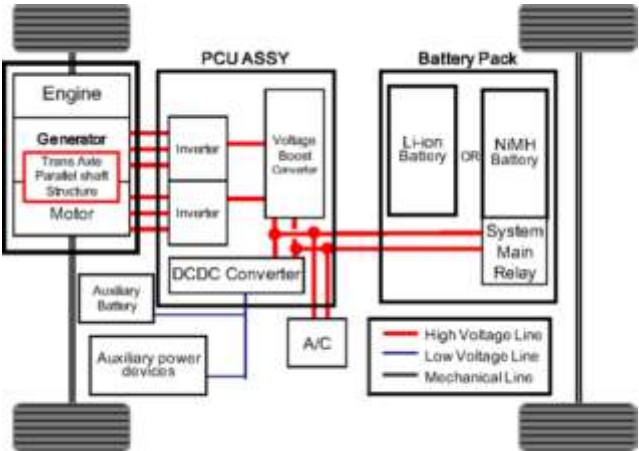

At 50,000 vehicles per year

	Prius eMachine	Prius Invertor	Chevy Volt	Audi eTron	iPace
Peak power	53kW		48kW		140kW
"should cost"	\$220 (x2)	\$670	\$200 (x2)	\$750	?
Value at 50k units per annum	\$22,000,000	\$33,500,000	\$20,000,000	\$37,500,000	?

Components	Prius eMachine	Prius Invertor	Chevy Volt	Audi eTron
Laminations rotor & stator	\$48			
Slot liner/separator	\$4		\$7	
varnish/resin	\$3		\$2	
Busbars	\$3	\$18		\$23
Wiring harnesses		\$25		\$16
Thermal conducting compound		\$4		\$4
Enclosure/casting		\$36		\$46

Components	Prius eMachine	Prius Invertor	Chevy Volt	Audi eTron
Laminations rotor & stator	\$4,800,000			
Slot liner/separator	\$400,000		\$700,000	
varnish/resin	\$300,000		\$200,000	
Busbars	\$300,000	\$9,000,000		\$11,500,000
Wiring harnesses		\$1,250,000		\$8,000,000
Thermal conducting compound		\$200,000		\$2,000,000
Enclosure/casting		\$18,000,000		\$23,000,000

Supply chain opportunity – processes lamination cutting, assembly and bonding

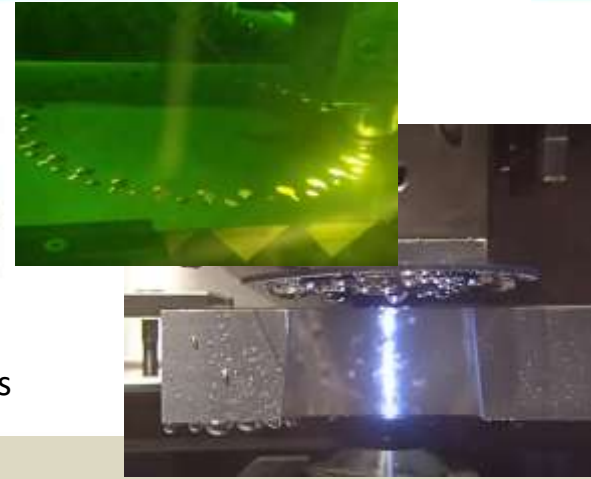
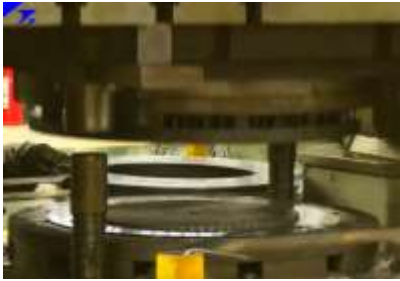

Single stamping, progression stamping, laser cutting, spark erosion of laminations

Lamination stacks – robotic handling, welding and adhesives

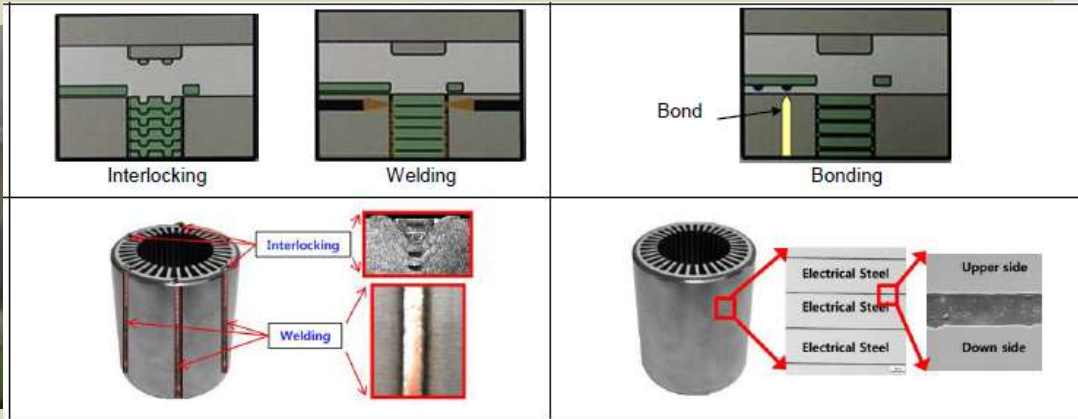

Innovation in technology in eMachines – increase the power density

- Thermal management
 - Stator water jacket – improvements to **casting** techniques (thinner walls)
 - Direct cooling (air / oil / water) – **new additives for coolants**
 - High temperature insulation – **new materials (PEEK)**
 - High temperature magnets – **or remove magnets**

Torque defines motor size at given cooling
For same power, higher speed means smaller motor

- High speed operation
 - Rotor mechanical strength – **new materials – carbon fibre**
 - Control of losses – **improved laminations and windings**
 - Reduction gearing – **improved gears** (reduce losses)
 - Noise & Vibration – **coatings on gears, novel gear materials**
 - Dynamic stability & resonance – **cladding materials**

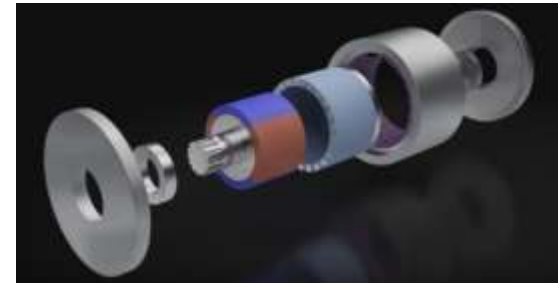

In conclusion - almost

- ▶ Automotive applications are complex.
 - Need to fit in a space envelope
 - Work over a range of operating cycles
- ▶ Vehicle concepts change - autonomy
 - Changes in the requirements for the electric drive system
 - Opportunities for new suppliers
- ▶ Challenges and opportunities shared across applications
 - Automotive – logistics
 - Aerospace – Uber Air, E-Fan X (Airbus)
 - Industrial – earth movers (on-site energy source)
 - Maritime -
- ▶ Cost effective high volume manufacturing requires innovation



<http://www.scania.com/group/en/scania-tests-next-generation-electric-vehicles/>

Winding Centre of Excellence at WMG by 2022

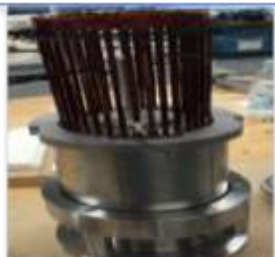

Discrete hairpin winding



Continuous hairpin winding

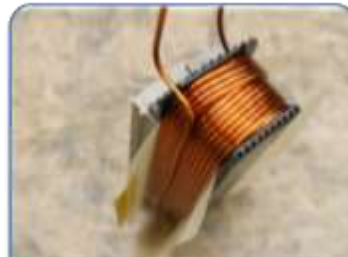

Concentrated winding



Magnet insertion and magnetisation



In process and electrical testing

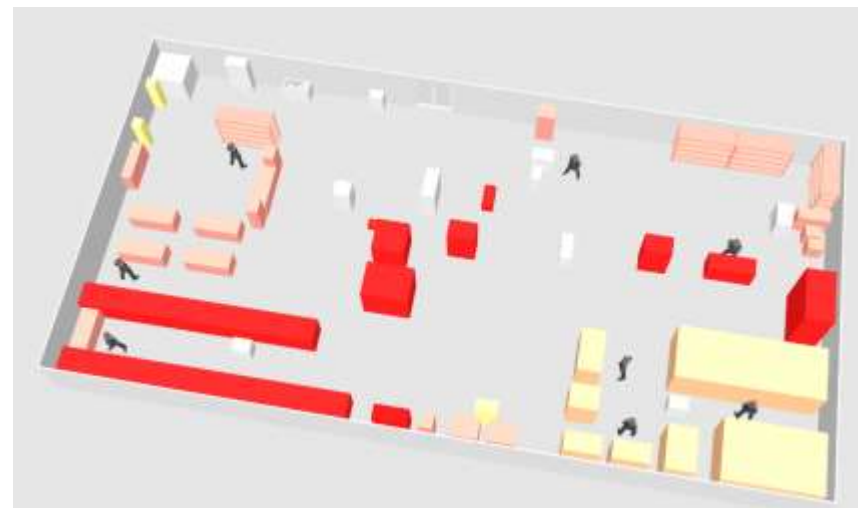

Thank you

wmgbusiness@warwick.ac.uk